

ABS & uPVC VALVES

CVW RANGE

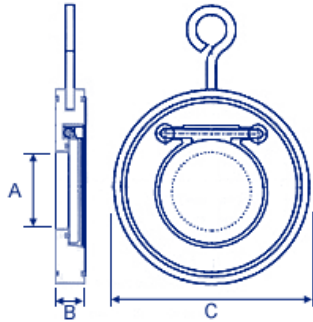

uPVC WAFER SWING CHECK VALVE

Part No. CVW-50P

WAFER SWING CHECK VALVE WITH uPVC BODY & EPDM SEALS

The CVW wafer pattern swing check valve is designed to be sandwiched between flanges.

uPVC is lightweight and has excellent resistance to chemicals and abrasion, is tasteless and odourless making it ideal for use with potable water systems and most food products. uPVC is resistant to most solutions of acids, alkalis, salts and solvents which can be mixed with water.

Features & Benefits

- WRAS Approved.
- uPVC Approved to BS4346 part 1.
- Lightweight.
- Full bore.
- Materials suitable for a wide range of applications.

Pressure & Temperature

Pressure range:-
Up to 10 bar

Temperature Range:-
0°C to 60°C.

A	1 1/4	1 1/2	2	2 1/2	3	4	5	6	8	10	12
B	85	95	109	130	144	164	192	220	276	330	380
C	15	16	20	20	20	22	22	26	35	40	45