



Cold
water

JOHNSON
valves

t +44 (0) 23 8066 9666

f +44 (0) 23 8066 9606

sales@johnsonvalves.com



MTK

Multijet domestic water meter
for cold water up to 30 °C
DN 15, 20, 25, 32, 40, 50

Your benefits

- Long service life, robust domestic water meter:
Excellent measuring stability and reliability
- Measurement of low flow rates:
Increased cost effectiveness

Application

- The MTK domestic water meter is suited for consumption reading of low to middle flow rate measurement typically in the utilities sector

Features

- Multijet impeller wheel, super dry-dial, magnetic coupling
- Q₃ 2,5: Measuring range R100
- Q₃ 4-25: Measuring range R160
- Easy to read roller counter due to large white figures on black background
- 5 dial resolution without comma place
- Maximum operation pressure PN 16 bar
- Maximum operating temperature 30 °C
- Horizontal or vertical installation (Vertical riser/down pipe)
- High grade wear resistant and corrosion proof materials
- Inlet strainer
- Reconditionable and recyclable execution
- Materials suited for contact with potable water
-  Conformity according to European Measuring Instruments (MID)

Options

- MTKcoder® MP-register for remote readout
 Documentation: MTKcoder® MP - EPe10121
- NPSM threaded connection (only for horizontal housing)
- Different pulse values
 Documentation: IPG14 - EPe40217

Technical Data

Execution			MTK (horizontal)						MTK-VS or -VF (vertical) ¹⁾			
Nominal diameter	DN	mm	15	20	25	32	40	50	20	25	32	40
Connection thread on meter	G...B	Inch	1	1	1¼	1½	2	2 ¾/8	1	1¼	1½	2
Connection thread on coupling	R...	Inch	¾ ²⁾	¾ ²⁾	1	1¼	1½	2	¾ ²⁾	1	1¼	1½
Operating pressure	PN	bar	16	16	16	16	16	16	16	16	16	16
Nominal flow rate	Q ₃	m ³ /h	2,5	4	6,3	10	16	25	4	6,3	10	16
Overload flow rate ³⁾	Q ₄	m ³ /h	3,125	5	7,875	12,5	20	31,25	5	7,875	12,5	20
Transitional flow rate ±2%	Q ₂	m ³ /h	0,04	0,04	0,063	0,1	0,16	0,25	0,04	0,063	0,1	0,16
Minimum flow rate ±5%	Q ₁	m ³ /h	0,025	0,025	0,039	0,062	0,1	0,156	0,025	0,039	0,062	0,1
Smallest readable volume		l	0,05	0,05	0,05	0,05	0,05	0,05	0,05	0,05	0,05	0,05
Maximum register reading		m ³	100'000	100'000	100'000	100'000	100'000	100'000	100'000	100'000	100'000	100'000
Temperature		max. °C	30	30	30	30	30	30	30	30	30	30
Measuring range			R100	R160	R160	R160	R160	R160	R160	R160	R160	R160

Dimension an weights			MTK (horizontal)						MTK-VS or -VF (vertical) ¹⁾			
Length without couplings	A	mm	165	190	260	260	300	300	105	150	150	200
Length with couplings		mm	257	282	352	372	432	452	197	242	262	332
Total height	B	mm	116	116	135	135	149	163	-	-	-	-
Total height with Reed pulser	B1	mm	131	131	150	150	164	178	-	-	-	-
Meter height from pipe centre line	C	mm	76	76	89	89	103	106	-	-	-	-
Meter height with Reed pulser from pipe centre line	C1	mm	91	91	104	104	118	121				
Meter depth	D	mm	-	-	-	-	-	-	148	169	183	226
Meter depth from pipe centre line	E	mm	-	-	-	-	-	-	130	143	156	190
Meter width	F	mm	95	95	100	100	135	151	95	98	101	139
Meter height with open lid	G	mm	193	193	212	212	226	240	-	-	-	-
Weight without couplings		app. kg	1,9	1,9	2,6	2,7	5,4	6,7	-	-	-	-
Weight without couplings MTK-VS		app. kg	-	-	-	-	-	-	1,9	3,0	3,0	6,0
Weight without couplings MTK-VF		app. kg	-	-	-	-	-	-	2,0	3,4	3,7	7,3
Weight with couplings		app. kg	2,2	2,2	3,1	3,4	6,5	8,3	-	-	-	-
Weight with couplings MTK-VS		app. kg	-	-	-	-	-	-	2,2	3,5	3,7	7,1
Weight with couplings MTK-VF		app. kg	-	-	-	-	-	-	2,3	3,9	4,4	8,4

Certifications	MTK (horizontal)						MTK-VS or -VF (vertical) ¹⁾				
SVGW certification	x	x	x	x	x	x	x	x	x	x	x
UBA Brass (DIN 50930-6)	x	x	x	x	x	x	x	x	x	x	x
KTW / W270	x	x	x	x	x	x	x	x	x	x	x
NSF-61-G & 372	-	-	x ⁴⁾	-	x ⁴⁾	-	-	-	-	-	-

¹⁾ -VS = Vertical riser / -VF = Vertical down pipe
⁴⁾ only in NPSM execution

²⁾ Also supplied with couplings R½

³⁾ Max. 1 h per 24 h, with max. total time of 100 h

Information	
EU-REACH Art. 33 / ChemV Art. 71	Brass products contain lead > 0,1 %

Dimension Diagram

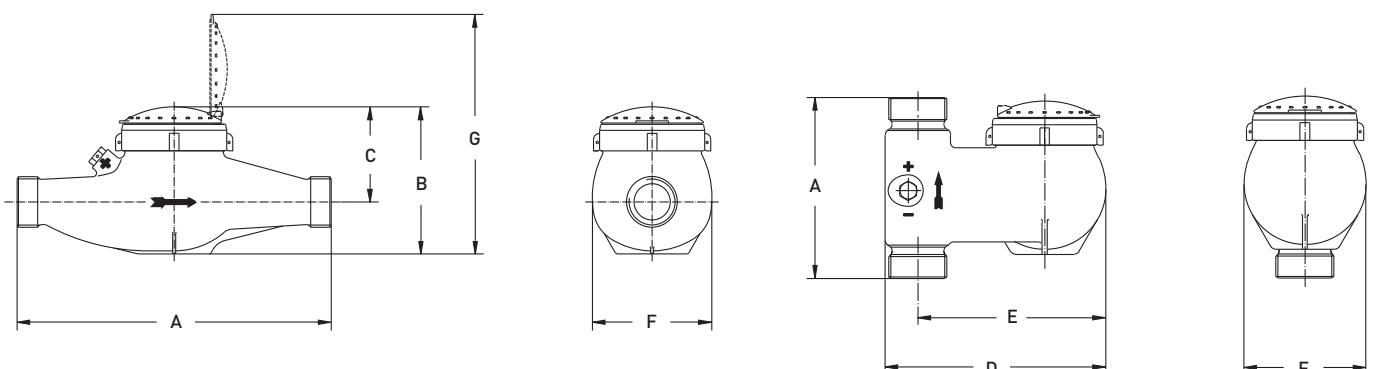

Materials

Housing:	UBA Brass (DIN 50930-6)
Sealing plate:	UBA Brass (DIN 50930-6)
Impeller/measuring insert:	High grade synthetic materials
Bearings:	Hard metal, Sapphire, Chrome nickel
Seal material:	EPDM

Measuring error curve

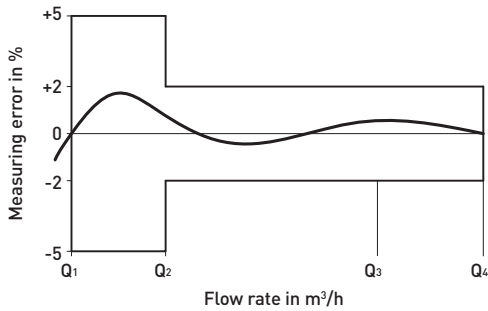

Typical Head Loss Curve

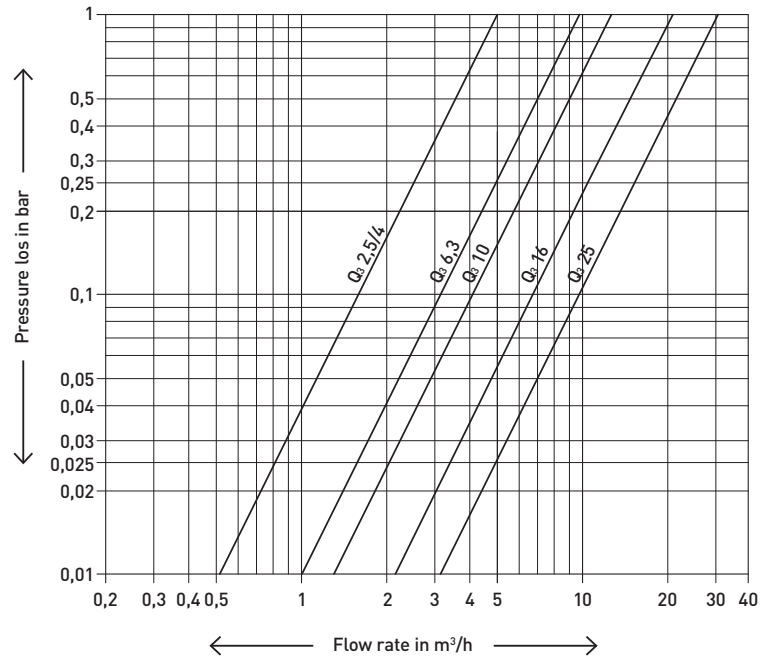

Installation

Pipeline:	horizontal	—
	vertical	
Meter head:	upwards	↑

Installation Requirements

The meter must be installed so that the type plate is always horizontally positioned, facing upwards (do not tilt).

Documentation: GWF Water meter - BAAdfei10207

Pulse value table

Pulse values (1 Pulse = ...Liter)	Qs 2,5-10	1*	2,5	10	25	100	250
	Qs 16-25	-	2,5	10	25	100	250

*Only available in measuring range R40